

UGF20

Ultrasonic Gas Flowmeter

Description

There are many reasons for choosing the UGF20 Ultrasonic Gas Flowmeter. The unit has no moving parts and requires no maintenance. As an ultrasonic gas transit time flowmeter, it does not create an obstruction in the pipe; therefore, it does not produce a pressure drop. The meter is immune to pulsation damage and impervious to particulates. It is capable of measuring over a wide flow range, eliminating the need for multiple meters. The meter is programmed at the factory in accordance with your measurement parameters. Installation simply requires mounting the sensors and connecting the power and output wire leads. Once in the field, changes to operating parameters are easily accomplished using the membrane numerical and function key pad.

The UGF20 has an automatic gain control feature that compensates for the variation in signal amplitude caused by flow conditions such as pressure and flow rate. The unit also has an LCD display with LED backlight capable of displaying instantaneous flow rate, flow rate trend and total. The UGF20 has multiple, configurable outputs available; two 4–20 mA analog outputs, four open collector frequency outputs and one RS-422 output. This digital output eliminates errors from analog to digital conversions when the meter is interfaced with down line equipment. RS-422 allows drive capabilities of up to 4,000 feet.

Features

- No moving parts
- Reduced maintenance and cost of ownership
- Factory-programmed
- Flow velocity measurement free from gas properties
- Repeatability of $\pm 0.2\%$
- 4–20 mA, pulse output and digital RS-422
- Simple to use — no complicated procedures
- High resolution accuracy
- No flow obstruction — no pressure drop
- Automatic gain control
- Self-diagnosis function
- Bi-directional



UGF20
Ultrasonic Gas Flowmeter

System Configuration

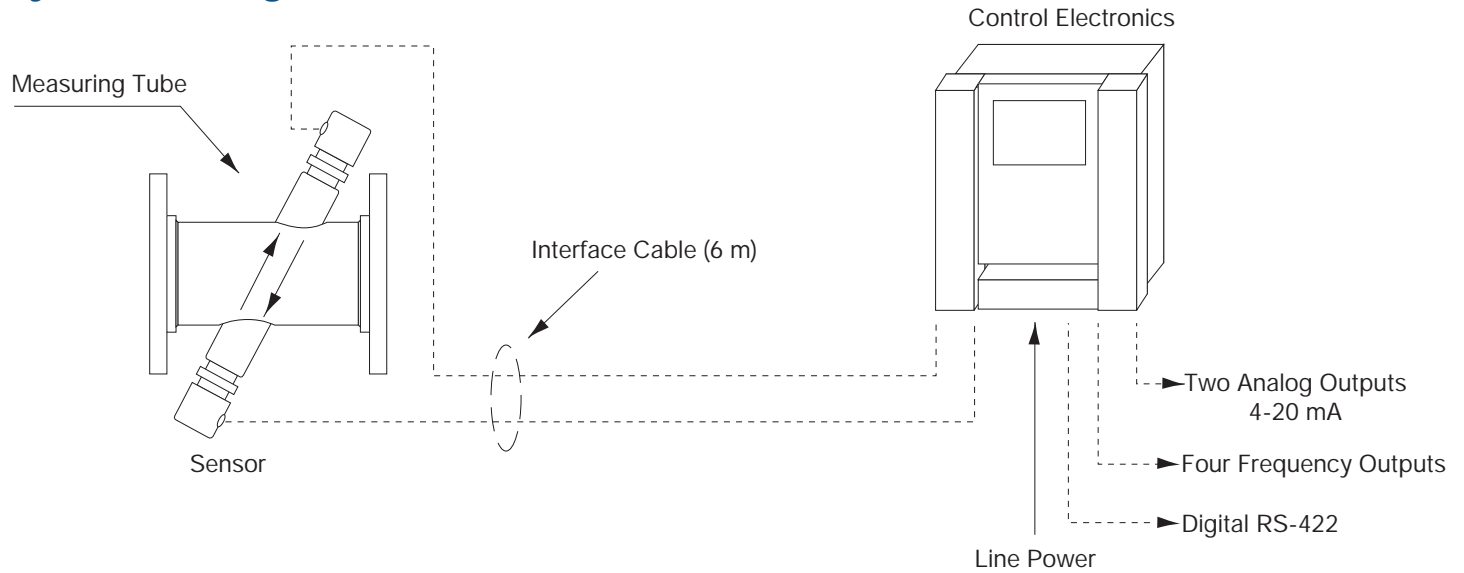

How The System Works

Flow Technology's UGF20 Ultrasonic Gas Flowmeter operates using the differential inverse transit time principle. Because the unit operates in a frequency mode, it provides high resolution, excellent repeatability and reliability. The transit time meter uses two diametrically opposed sensors. The sensors are mounted on an angle with respect to the axis of the piping so that one sensor is upstream of the other. Ultrasonic sound waves transmitted by the sensors alternate and are synchronized, allowing one to transmit while the other is receiving. The sensor positioning establishes the time differential as the sound is being carried downstream by the flow, and delayed while transmitting upstream. This difference in transit time is directly proportional to the velocity of the fluid being measured.

The mathematical derivation is as follows:

$$V = (L \times (1/t_u - 1/t_d)) / (2 \times \cos(T))$$

V = velocity of fluid in pipe

L = the distance between the ultrasonic sensors

t_u = flow upstream frequency

t_d = flow downstream frequency

T = angle between axis of sensors and axis of pipe

Note that the equation is independent of the speed of sound. This makes the velocity measurement insensitive to temperature and pressure since the speed of sound in gas is a strong function of temperature and pressure. Therefore, frequency domain meters are insensitive to temperature and pressure excursions since they are independent of the speed of sound. However, the velocity measurement is affected by changes in the flow profile of which the sound travels through. The flow profile is a function of the Reynolds Number which is affected by temperature and pressure. If the Reynolds Number is held above 3,000, the flow profile is relatively unaffected and temperature and pressure sensors should not be required.

Accuracy

It is recommended that a straight length of pipe equal to 15 diameters be installed upstream of the meter, and 5 diameters be installed downstream to stabilize the flow profile. A dual path configuration is offered to better define the velocity profile. The single path standard unit is capable of a measurement accuracy of $\pm 1\%$ with repeatability within $\pm 0.2\%$ over the flow range of the meter. The sensor can operate in temperatures from -4°F to 356°F (-20°C to 180°C) and pressures up to 145 psig (10 BAR G).



Dimensions

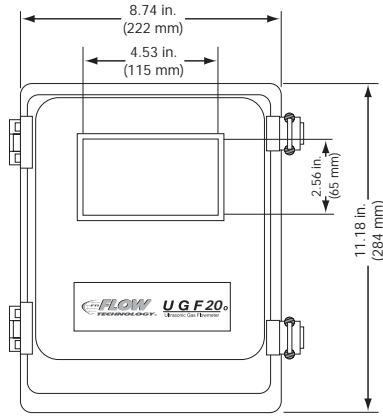

Front View

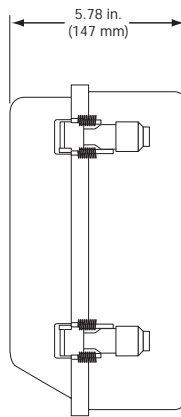

Side View

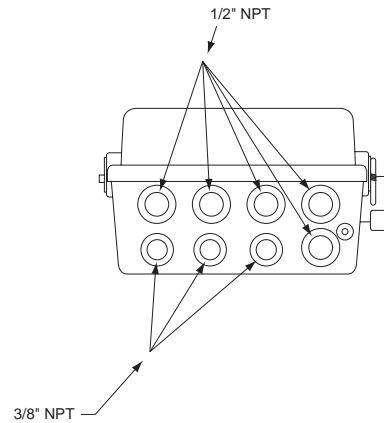

Bottom View

Drawings not to scale.

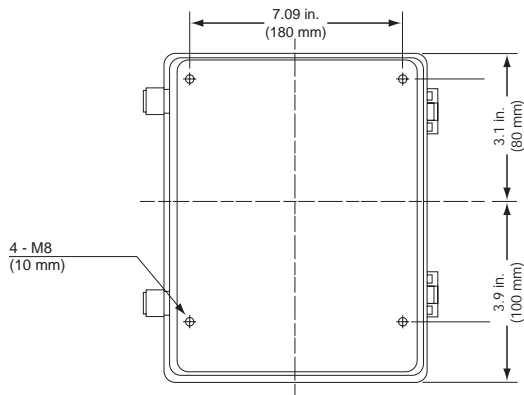

Electronic Enclosure Mounting Hole Dimensions

Measuring Range							
Model Number	Pipe Size Nominal	Pipe I.D.		Minimum Flow Rate		Maximum Flow Rate	
		inches	mm	ACFM	Am ³ /hr	ACFM	Am ³ /hr
02	2"	2.1	52.7	4.9	8.3	275.0	467.3
03	3"	3.1	78.1	10.8	18.3	604.5	1027.1
04	4"	4.0	102.3	18.6	31.6	1041.9	1770.4
06	6"	5.9	151.0	40.4	68.7	2262.6	3844.7
08	8"	7.9	199.9	70.9	120.5	3972.5	6750.3
10	10"	9.8	248.8	110.0	186.9	6159.9	10467.1
12	12"	11.7	297.9	156.8	266.4	8780.1	14919.5

Model Numbering System



Electronic Box

Power Source

- 1 = 115 VAC
- 2 = 220 VAC

Channel

- S = Single
- D = Dual

Cable Length

- 06 = 6 meters
- 10 = 10 meters

Meter Size

- 06 = 6" (151 mm)

Sensor Heads

- A = TS-121 Sensor Heads (required on 6" and smaller meters)

- B = TS-131 Sensor Heads (required on 8" and larger meters)

End Fittings

- C1 = 150# Raised Face Flange

Specifications

Pipe Sizes	Nominal 2" – 12" (50 – 305 mm)	Full Scale Operation	Available setting range up to 196 ft./sec. (60 m/s). (See flow range chart for typical ranges)
Applicable Gases	Gases and steam	Sensors	Premounted in flanged housing
Measurement Method	Inverse time difference calculation method of ultrasonic frequency propagation	Sensor Material	316 SS with a titanium alloy tip
Calculation Method	Digital calculation method by microprocessor	Housing Material	Zinc-plated C.S. Other materials available upon request
Measurement Accuracy	±1% FS	Power Sources	115 VAC, 220 VAC ±10%, 50/60 Hz
Repeatability	±0.2%	Cable	19.7 ft. (6 m) or 32.8 ft. (10 m) between sensor and main unit
Flow Velocity Resolution	1.18 in./min. (0.5 mm/s)	Electrical Enclosure	Cast aluminum with weatherproof gasket
Measuring Frequency	20 times per second	Conduit Tube Connection	1/2" (12.7 mm) internal NPT
Received Signal Amplitude Adjustment	Selection of auto or manual	Output Signal	
Environmental Temperature Range	14° F to 122° F (-10° C to 50° C)	Analog	4–20 mA, load resistance 600Ω or less
Sensor Temperature Range	-4° F to 356° F (-20° C to 180° C)	Pulse	Open collector, rated at 30 V 0.25 A
Maximum Operating Pressure	145 psig (10 BAR G)	Installation Condition	
		Straight Pipe Length (Diameters)	Upstream side – 15 or more Downstream side – 5 or more

Application Considerations

Gas To Be Measured: _____ **Composition:** _____

Temperature (°F): Min. _____ Nor. _____ Max. _____ **Pressure (psig):** Min. _____ Nor. _____ Max. _____

Measuring Range (ACFM): Min. _____ Nor. _____ Max. _____ **Base Density:** _____ lb./ft.³

Kind Of Pipe: _____ **Viscosity @ Norm. Temp.:** _____ CP

 Outside Diameter (in.): _____ **Power Supply Voltage (V):** _____

 Inside Diameter (in.): _____ **Path:** Single Dual

Reverse Flow: No Yes

Local Representative:



8930 S. Beck Avenue, Ste 107, Tempe, Arizona 85284 USA
Tel: (480) 240-3400 • Fax: (480) 240-3401 • Toll Free: 1-800-528-4225
E-mail: ftimarket@ftimeters.com • Web: www.ftimeters.com